

BRADFORD WHITE®

TTW2

Residential Through-The-Wall Energy Saver Gas Water Heater

Features:



Bradford White is ISO registered to the 9001-1994 standard.

- **Power vented for positive exhaust during main burner operation**—the TTW2 uses a specially designed assembly that blows exhaust gases directly out of the building, eliminating the need for conventional chimneys or expensive flue systems.
- **Electronic ignition system**—electronic ignition eliminates the constant burning pilot used on other water heaters. This device results in savings of pilot gas during standby periods. (115V AC required to heater) Ignition system operates off of 24 volts.
- **3" PVC, ABS & CPVC (76mm) vent**—the water heater can be vented horizontally or vertically with 3" (76 mm) PVC, ABS & CPVC for lengths up to 30 feet (9.1 m) with (3) 90° elbows. (45 equivalent feet) (13.7 m).
- **4" PVC, ABS & CPVC (102mm) vent**—the water heater can be vented horizontally or vertically with 4" (102mm) PVC, ABS & CPVC for lengths up to 60 feet (18m) with (3) 90° elbows. (75 equivalent feet) (23m).
- **Vitraglas® lining**—Bradford White water heater tanks are protected from the corrosive effects of hot water by an exclusive ceramic porcelain-like coating. The Bradford White high silica Vitraglas® lining provides a tough interior surface for our hot water tanks.
- **Side connections**—for space heating.
- **Protective magnesium rod**—provides added protection against corrosion for long trouble-free service.
- **Factory installed Hydrojet® Total Performance System**—cold inlet sediment reducing device. Helps prevent sediment build up in tank. Increases first hour delivery of hot water while minimizing temperature build up at top of tank.
- **Factory installed dielectric waterway fittings**—all heaters equipped with special water heater nipples for longer life.
- **2" Non-CFC foam insulation (65 gallon model has 1" Non-CFC foam)**—covers the sides and top of tank to save energy by retarding loss of heat. Also increases jacket rigidity.
- **Fully automatic controls**—fast acting surface-mount thermostat for automatic temperature control. Built-in energy cut-off switch prevents abnormally high water temperature for extra safety. Combination gas valve/electronic module has built-in gas pressure regulation and electronic circuit controls. Ignition system operates off of 24 volts.
- **Brass drain valve.**
- **T&P relief valve opening**—all sizes have special tapping on side of tank for ease of installing relief valves.
- **Flue baffle**—designed to maximize the amount of heat absorbed in the lower portion of tank. Reduces air movement in the heater during standby periods to retard heat loss up the flue.
- **Six or ten year limited warranty on steel tank**—heavy gauge steel automatically formed, rolled and welded to assure a continuous seam for glass lining.
- **Six year limited warranty on parts.**
- **Design certified by CSA International (formerly AGA and CGA).**

MANUFACTURED UNDER ONE OR MORE OF THE FOLLOWING U.S. PATENTS:
Re. 34,534; 4,416,222; 4,628,184; 4,669,448; 4,672,919; 4,808,356; 4,829,983;
4,861,968; 4,904,428; 5,000,893; 5,023,031; 5,052,346; 5,081,696; 5,092,519;
5,115,767; 5,199,385; 5,277,171; (B1)5,341,770; 5,372,185; 5,485,879; 5,574,822;
5,596,952; 5,660,165; 5,682,666; 5,761,379; 5,943,984; 5,954,492; 5,988,117;
6,142,216. OTHER U.S. AND FOREIGN PATENT APPLICATIONS PENDING.
CURRENT CANADIAN PATENTS: 1,272,914; 1,280,043; 1,289,832; 2,045,862;
2,112,515.

EFFICIENCY
RATING
CERTIFIED
ama



Through-The-Wall Gas Water Heater

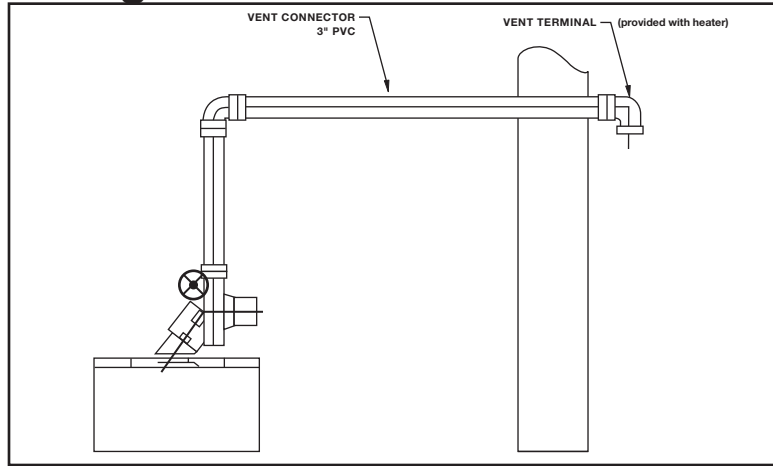
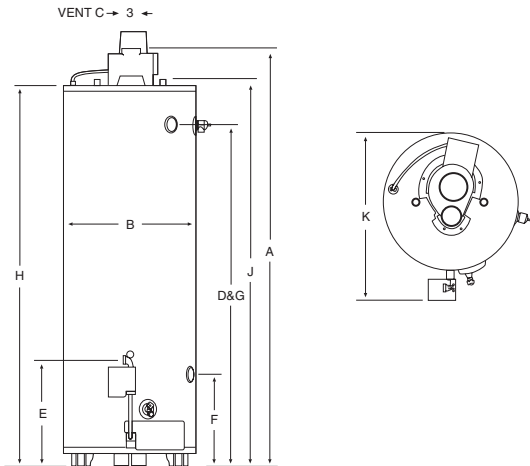

Deluxe Energy Saver Models (Meet or exceed ASHRAE 90.1b current standard) C.E.C. Listed 80% Recovery Efficiency

NATURAL GAS Model Number	Imp. Gal. Cap.	U.S. Gal. Cap.	Liters	BTU Input	KW BTU	Recovery 50°C Rise/90°F Rise*			A Floor to Flue Conn.		B Jacket Dia.		C Vent Size		D Floor to T&P Conn.		E Floor to Gas Conn.		F Floor to Space Heating Return		G Floor to Space Heating Outlet		H Floor to Water Conn.		Approx. Shipping Weight lbs. kg	
						Imp. GPH	U.S. GPH	Liters/Hr	In.	mm	In.	mm	In.	mm	In.	mm	In.	mm	In.	mm	In.	mm	In.	mm		
M-II-TW-50T6EN ^(LP)	40	48	182	65,000	19.1	58	70	265	63¼	1607	22	559	3	76	48¼	1243	16¼	422	14½	368	48¼	1243	58	1473	188	85
M-II-TW-65T6EN ^(LP)	54	65	246	65,000	19.1	58	70	265	66¼	1695	22	559	3	76	54¼	1384	16¼	425	17½	445	54¼	1384	61½	1562	222	101
M-II-TW-75T6EN	62	75	284	76,000	22.3	67	82	310	66	1676	26	660	3	76	53	1346	19	483	16¼	427	53	1346	60¼	1543	277	126

All propane heaters are equipped with a cast iron burner. To order a propane heater change suffix "EN" to "CX". For 10 year models, change suffix from "6" to "10".
*Based on manufacturers rated recovery efficiency.

^(LP) Propane Gas Inputs	Recovery at 50°C Rise and 90°F Rise				
	Imp GPH	US GPH	Liters/Hr		
M-II-TW50T6CX	18.5 KW	63,000 BTU/Hr	57	68	257
M-II-TW65T6CX	18.5 KW	63,000 BTU/Hr	57	68	257

110 V.A.C. Required for Power Venting
110 V.A.C. 60HRZ 2.1 Amperes

MAXIMUM HORIZONTAL AND VERTICAL VENT

3" PVC, ABS & CPVC (76mm)† 30 ft. (9.1 m)
4" PVC, ABS & CPVC (102mm)† 60 ft. (18 m)
(3) 90° elbows

† Note: For high altitude installation, consult installation instructions

All natural gas models meet SCAQMD Requirements.

Meets NAECA Requirements

General

All gas water heaters are certified at 300 PSI test pressure (2068 kPa) and 150 PSI working pressure (1034 kPa). All water connections are ¾" NPT (19mm) on 11" (279mm) centers, all gas connections ½" (13mm). All models design certified by CSA International (formerly AGA/CGA) and peak performance rated.

Dimensions and specifications subject to change without notice in accordance with our policy of continuous product improvement.

6-Year Limited Warranty on Component Parts

BRADFORD WHITE CORPORATION has a 6-year warranty on replaceable parts – gas valve, thermostat, burner, dip tube, drain valve and blower assembly. These quality components are manufactured for us by industry leaders and will be replaced in the event of failure during the parts warranty period (exclusive of shipping and re-installation cost.)§

§ Some states do not allow limitations on warranties. For product installed in the USA, Canada and Puerto Rico. See complete copy of the warranty included with the heater.

6 or 10-Year Limited Tank Warranties

BRADFORD WHITE CORPORATION LIMITED WARRANTY: Protects your investment in a quality glass-lined heater. If the tank leaks for reasons of faulty materials, workmanship, or corrosion within the warranty period, the heater will be replaced with a comparable heater of our manufacture (exclusive of shipping and re-installation cost.)§



Ambler, PA

Sales/800-538-2020
800-532-4020
Fax/215-641-1670
Service/800-334-3393
Fax/616-795-1089
Warranty/800-531-2111
Fax/616-795-1089

International:
Telephone/215-641-9400
Telefax/215-641-9750

In Canada:
Sales/800-523-2931
Fax/215-641-9750
Service/800-334-3393
Fax/616-795-1089
Fax On Demand
888-538-7833

Vitraglas® and Hydrojet® are registered trademarks of Bradford White® Corporation.
©2002, Bradford White Corporation. All rights reserved.